

The Crystal and Molecular Structure of D-Glucono-(1,5)-lactone*

BY M. L. HACKERT AND R. A. JACOBSON

Institute for Atomic Research and Department of Chemistry, Iowa State University, Ames, Iowa 50010, U.S.A.

(Received 24 November 1969)

The crystal structure of D-glucono-(1,5)-lactone has been determined by three-dimensional X-ray analysis. The crystals are orthorhombic, space group $P2_12_12_1$, $a=7.838$ (1), $b=12.332$ (2), $c=7.544$ (1) Å and $Z=4$. The structure was solved using Patterson map-symmetry map superposition techniques. Full-matrix, weighted, least-squares refinement gave a final agreement index of $R=0.046$ for 974 observed reflections recorded by counter methods using a $\theta-2\theta$ step scan technique and Zr-filtered $\text{MoK}\alpha$ radiation. The restraint of the planar carbonyl group imposes a distorted half-chair conformation on the δ -lactone ring system. Extensive intermolecular hydrogen bonding occurs throughout the crystal.

Introduction

The crystal structure of D-glucono-(1,5)-lactone has been determined because a knowledge of the molecular conformation of a typical aldolactone in the solid state may be relevant to an understanding of the manner in which these compounds inhibit glycosidases and other enzymes of carbohydrate metabolism. Preliminary results of this investigation have been reported previously (Hackert & Jacobson, 1969). All non-hydrogen positions were determined with the aid of a symmetry map and the Patterson superposition technique. We feel that this method, or a modification of it, is generally applicable for moderately sized molecules.

Experimental

Crystal data

$\text{C}_6\text{H}_{10}\text{O}_6$, $M=178.14$ g.mol⁻¹. Orthorhombic $P2_12_12_1$,
 $a=7.838 \pm 0.001$, $b=12.332 \pm 0.002$,
 $c=7.544 \pm 0.001$ Å, $V=729.2$ Å³, $D_c=1.62$ g.cm⁻³,
 $Z=4$, $F(000)=376$, $\text{Mo K}\alpha(\lambda=0.7107$ Å),
 $\mu=1.60$ cm⁻¹.

Suitable crystals were obtained by recrystallizing commercially available glucono- δ -lactone from a saturated DMF (dimethylformamide) solution allowed to evaporate slowly. The colorless crystals grew with **b** perpendicular to, and **a** and **c** along, the diagonals of the broad face. Precession and Weissenberg photographs exhibited *mmm* Laue symmetry with alternate extinctions along the axes indicating the orthorhombic space group $P2_12_12_1$. The unit-cell parameters and their standard deviations were obtained by a least-squares fit to 14 independent reflection angles whose centers were determined by left-right, top-bottom beam splitting on a previously aligned Hilger-Watts four-circle diffractometer (Mo $K\alpha$ radiation). Any error in the instrumental zero was eliminated by centering the reflection at both

+2 θ and -2 θ . The lattice parameters obtained agree well with those found by Jeffrey (1968).

A crystal of dimensions 0.24 × 0.20 × 0.12 mm was mounted on a glass fiber with **b** along the spindle axis for data collection. Intensity data were collected at room temperature (24°C) using a fully automated Hilger-Watts four-circle diffractometer equipped with scintillation counter and interfaced with an SDS-910 computer in a real-time mode. Two equivalent octants of data were collected using Zr-filtered Mo $K\alpha$ radiation within a θ sphere of 35° ($\sin \theta/\lambda=0.8071$). The $\theta-2\theta$ step-scan technique, 0.01°/step counting for 0.4096 sec/step was employed with a take-off angle of 4.5°. To improve the efficiency of the data collection process, variable-step symmetric scan ranges were used. The number of steps used for a particular reflection was 50+2 per degree θ . Individual backgrounds were obtained from stationary-crystal stationary-counter measurements for one-half the total scan time at each end of the scan.

The intensities of three standard reflections were measured periodically during the data collection. Monitoring options based on these standard counts were employed to maintain crystal alignment and to stop the data collection process if the standard counts fell below statistically allowed fluctuations. A total of 3762 reflections were recorded in this manner.

The intensity data were corrected for Lorentz-polarization effects. Because of the small linear absorption coefficient, no absorption correction was made. The minimum and maximum transmission factors were 0.96 and 0.98 respectively. Because absorption was negligible, the consistency of equivalent data was easily checked. Those equivalent reflections differing by more than $5\sigma=5\sqrt{(TC)}$ were retaken. This affected some 150 reflections. The individual values of F_o^2 from the equivalent octants were then averaged to yield 1851 independent F_o^2 values. Standard deviations in the intensities (σ_I) were estimated from the average total count (TC) and background (BK) values by

$$(\sigma_I)^2 = TC_{av} + BK_{av} + (0.05*TC_{av})^2 + (0.05*BK_{av})^2 .$$

* Work performed at the Ames Laboratory of the U.S. Atomic Energy Commission. Contribution No. 2647.

Of the 1851 independent reflections, 974 had $F_o^2 > 2.5\sigma_I$. These were used in the initial stages of refinement. The weights used in the least-squares refinement were $w = 1/(\sigma_F)^2$ where $\sigma_F = [(I + \sigma_I)/Lp]^{1/2} - F_o$. When all atom positions were located, final weighted least-squares refinement was completed using all of the independent reflection data.

Solution and refinement of the structure

The observed data were used to compute an unsharpened Patterson map. The resulting map contained many broad, overlapping peaks which made it unsuitable for superposition techniques. To reduce the peak width, sharpened coefficients were computed by

$$|F_{hkl}^s|^2 = [|F_{hkl}^o| / (f^k)]^2 \exp [(2B - B') \sin^2 \theta / \lambda^2],$$

where $f = \sum f_j / \sum Z_j$, k is a scale factor, B is the overall isotropic temperature factor, and B' is a variable used to minimize rippling resulting from sharpening. Estimates of the overall temperature and scale factors were obtained from a Wilson plot. A sharpened Patterson map of good resolution was obtained using $2B - B' = 2.0 \text{ \AA}^2$.

Examination of the sharpened Patterson map, and initial superposition attempts produced no realistic model; therefore a symmetry map (Mighell & Jacobson, 1963) was next calculated. The value assigned to each point of the symmetry map was obtained by taking the minimum of the values of the associated points on the three Harker planes. In order that no information on these planes be discarded, the maximum value at the point and the four other points immediately surrounding it in the plane was taken before carrying out the minimum procedure. After a couple of unpromising choices, a single peak was selected from the 64 images of the orthorhombic unit cell present in the symmetry map and a set of four symmetry map-Patterson map superpositions was carried out. Analysis of the resulting map showed that there were only 32 consistent, independent peaks remaining. A second peak was chosen from what appeared to be the same image and another set of four such superpositions was carried out. Analyzing the resultant map and comparing it with the first reduced the number of possible peak positions to 18 with a fragment of the molecule now readily observable. A third peak was chosen from the visible fragment and another set of superpositions

Table 1. Final heavy-atom atomic coordinates and thermal parameters*†

	<i>x</i>	<i>y</i>	<i>z</i>	β_{11}	β_{22}	β_{33}	β_{12}	β_{13}	β_{23}
C(1)	0.2071 (4)	0.2214 (2)	0.4968 (3)	99 (4)	44 (2)	74 (4)	-4 (2)	0 (4)	3 (2)
C(2)	0.1911 (3)	0.1294 (2)	0.6312 (3)	82 (4)	30 (1)	86 (4)	3 (2)	2 (4)	2 (2)
C(3)	0.1067 (3)	0.1632 (2)	0.8022 (3)	81 (4)	36 (1)	69 (4)	6 (2)	8 (4)	9 (2)
C(4)	0.1868 (4)	0.2678 (2)	0.8653 (3)	96 (4)	30 (2)	67 (4)	6 (2)	1 (3)	4 (2)
C(5)	0.1586 (4)	0.3581 (2)	0.7304 (3)	100 (4)	36 (1)	68 (4)	7 (2)	-0 (4)	4 (2)
C(6)	0.2550 (3)	0.4599 (2)	0.7670 (4)	111 (4)	33 (2)	78 (4)	-2 (2)	-1 (3)	-0 (2)
O(1)	0.2238 (3)	0.2023 (2)	0.3407 (2)	220 (5)	56 (2)	72 (3)	-16 (2)	16 (3)	-0 (2)
O(2)	0.1041 (3)	0.0415 (1)	0.5520 (2)	122 (4)	35 (1)	118 (3)	-3 (2)	7 (3)	-12 (2)
O(3)	0.1304 (3)	0.0782 (2)	0.9627 (3)	135 (4)	38 (1)	98 (3)	15 (2)	24 (3)	22 (2)
O(4)	0.1097 (3)	0.3061 (2)	1.0248 (2)	192 (5)	47 (1)	71 (3)	8 (2)	19 (3)	0 (2)
O(5)	0.2100 (3)	0.3233 (1)	0.5521 (2)	219 (5)	37 (1)	60 (3)	-13 (2)	8 (3)	3 (2)
O(6)	0.4331 (3)	0.4429 (2)	0.7852 (3)	103 (4)	69 (2)	102 (4)	9 (2)	-6 (3)	9 (2)

* Standard errors of the coordinates and the β_{ij} and their standard errors are $\times 10^4$. The β_{ij} are defined by:

$$T = \exp [-(h^2\beta_{11} + k^2\beta_{22} + l^2\beta_{33} + 2hk\beta_{12} + 2hl\beta_{13} + 2kl\beta_{23})].$$

† Numbers in parentheses here and in succeeding Tables are estimated standard deviations in the last significant digits.

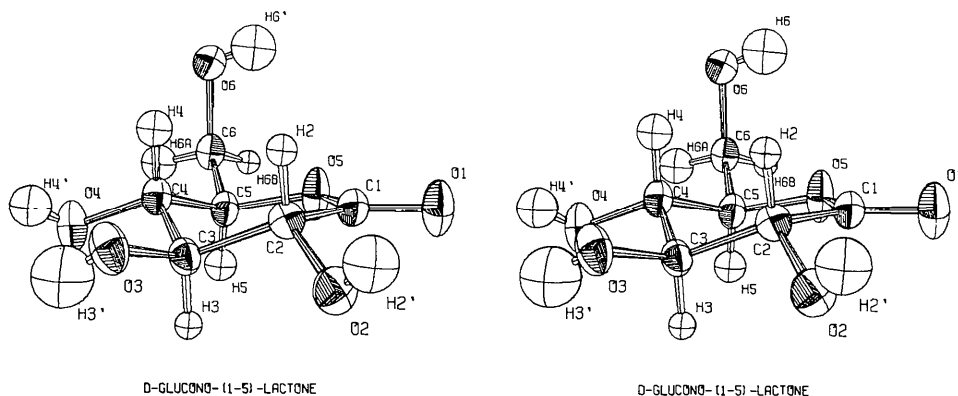

Fig. 1. Stereogram of molecule with thermal ellipsoids scaled to enclose 50% probability.

made. Comparison of the three maps easily resolved the previous ambiguities, locating all carbon and oxygen atom positions. Further details of the method have been reported (Jacobson, 1970).

Three cycles of full-matrix least-squares refinement of these heavy-atom positional and isotropic thermal parameters gave a conventional discrepancy index $R = \sum ||F_o| - |F_c|| / \sum |F_o| = 0.109$ and a weighted R value $\omega R = [\sum \omega (|F_o| - |F_c|)^2 / \sum \omega |F_o|^2]^{1/2} = 0.133$ for the 974 observed reflections. The scattering factors used for carbon and oxygen were those of Doyle & Turner (1968). A difference electron density map at this stage showed that all the non-hydrogen atoms had been accounted for, but that some anisotropic motion was evident. Anisotropic refinement of all heavy atom positions for two additional cycles lowered the discrepancy index to $R = 0.071$ and $\omega R = 0.090$. The following difference electron density map clearly indicated the positions of all hydrogen atoms bound to carbon atoms. These positions were input, lowering the agreement

index to 0.057, but some of the isotropic thermal parameters went negative. This was attributed to the use of the isolated hydrogen atom scattering factor, leading to an undesirable interaction between the thermal parameter and aspherical electron density distribution for bound hydrogen, as described by Jensen & Sundaralingam (1964). Using the contracted hydrogen atom scattering factor of Stewart, Davidson & Simpson (1965), positive isotropic thermal parameters were derived. All remaining hydrogen atom positions were obtained from subsequent difference electron density maps. Final values of R and ωR of 0.046 and 0.051 respectively, were obtained for the 974 observed reflections. At this point two final cycles of weighted least-squares refinement of all parameters were run using all 1851 independent reflections recorded, the results being $R = 0.095$ and $\omega R = 0.049$. No appreciable shifts occurred. A final electron density difference map showed no peak heights greater than $0.3 \text{ e.}\text{\AA}^{-3}$. A statistical analysis of $\omega \Delta^2$ [where $\Delta^2 = (|F_o| - |F_c|)^2$] as a

Table 2. Refined hydrogen atom parameters

	<i>x</i>	<i>y</i>	<i>z</i>	<i>B</i>
H(2)	0.308 (3)	0.108 (2)	0.654 (3)	1.4 (5) Å ²
H(3)	-0.013 (3)	0.172 (2)	0.785 (3)	1.2 (5)
H(4)	0.308 (3)	0.261 (2)	0.879 (3)	2.1 (6)
H(5)	0.044 (3)	0.373 (2)	0.728 (4)	2.1 (6)
H(6A)	0.218 (4)	0.488 (2)	0.877 (4)	2.8 (6)
H(6B)	0.235 (3)	0.514 (2)	0.680 (3)	1.3 (5)
H(2')	0.162 (4)	-0.002 (2)	0.509 (4)	3.9 (8)
H(3')	0.077 (5)	0.089 (3)	1.000 (5)	5.0 (10)
H(4')	0.147 (4)	0.277 (2)	1.100 (4)	2.8 (8)
H(6')	0.473 (4)	0.433 (3)	0.696 (5)	4.2 (9)

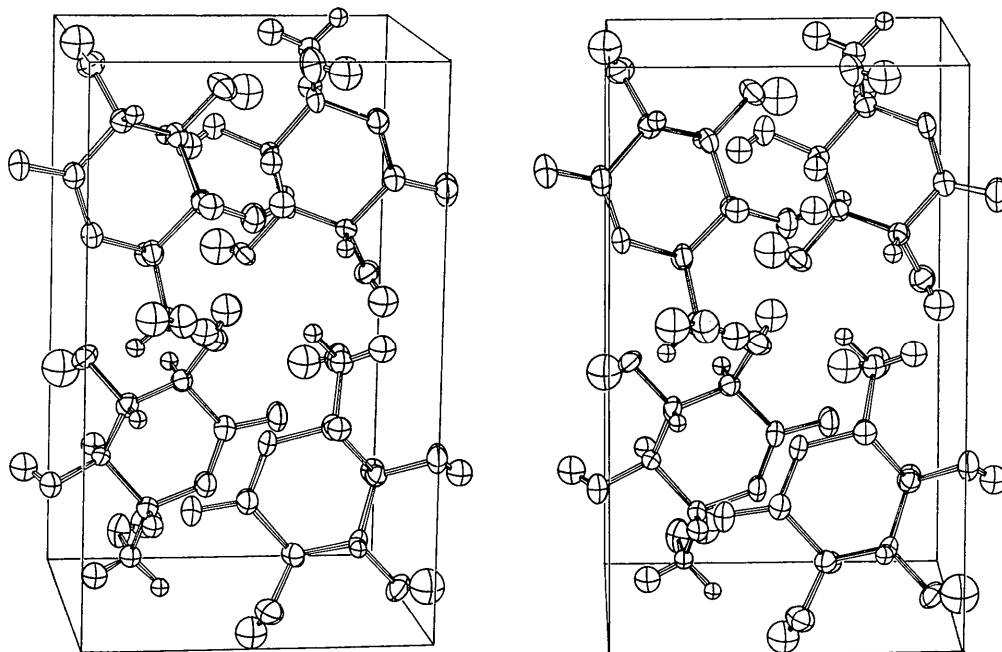

Fig. 2. Packing diagram of the unit cell.

given in Table 4 and shown in Fig. 3. The estimated standard deviations were calculated using the variance-covariance matrix and *ORFFE* program.

Description and discussion of the structure

The planarity of the carbonyl group imparts a distorted half-chair conformation to the ring of the D-glucono-(1,5)-lactone molecule. The CH₂OH and OH groups occupy the most equatorial positions possible as shown in Fig. 1. The bond distances and angles are in generally good agreement with those reported in the literature. The average C-C and C-OH distances are 1.51 and 1.42 Å respectively, compared with 1.52 and 1.42 Å reported in the neutron diffraction study of α-D-glucose (Brown & Levy, 1965). The C(5)-O(5) distance is significantly longer, however, being 1.47 Å. The C(1)-O(1) and C(1)-O(5) distances are 1.21 and 1.32 Å, typical of the distances found in normal esters. Peaks at 1740 and 1225 cm⁻¹ in the infrared spectrum

substantiate this comparison. The angles about C(1) are all nearly 120° in accordance with the expected *sp*² hybridization. The only other angles which differ appreciably from the tetrahedral angle of 109.5° are C(1)-O(5)-C(5) and C(4)-C(5)-C(6), the former being 124°, substantially larger than the 114° found in α-D-glucose.

The conformation of six-membered rings involving a planar group has been studied by Mathieson (1963). Either a boat or a half-chair conformation is possible with a planar restraint on four of the six ring atoms. The planarity of the C-C-O-C group is associated



with the valence bond contribution of the resonance form $\text{C}=\overset{+}{\text{O}}-\text{C}$. From geometrical considerations it



was suggested that rings containing the carbon-carbon

Table 4. *Interatomic distances and angles**

(a) Distances		E.s.d. = 0.003 Å	
C(1)-C(2)	1.527 Å	C(1)-O(1)	1.208 Å
C(2)-C(3)	1.508	C(1)-O(5)	1.324
C(3)-C(4)	1.512	C(2)-O(2)	1.414
C(4)-C(5)	1.525	C(3)-O(3)	1.419
C(5)-C(6)	1.491	C(4)-O(4)	1.427
		C(5)-O(5)	1.468
		C(6)-O(6)	1.418

(b) Angles		E.s.d. = 0.2°	
C(2)-C(1)-O(1)	120.7°	C(3)-C(4)-C(5)	110.7°
C(2)-C(1)-O(5)	119.8	C(3)-C(4)-O(4)	111.9
O(1)-C(1)-O(5)	119.4	C(5)-C(4)-O(4)	105.1
C(1)-C(2)-C(3)	113.5	C(4)-C(5)-C(6)	114.7
C(1)-C(2)-O(2)	109.2	C(4)-C(5)-O(5)	111.0
C(3)-C(2)-O(2)	111.2	C(6)-C(5)-O(5)	106.1
C(2)-C(3)-C(4)	108.8	C(5)-O(5)-C(1)	124.1
C(2)-C(3)-O(3)	107.8	C(5)-C(6)-O(6)	113.1
C(4)-C(3)-O(3)	111.5		

* See Fig. 3 for distances and angles associated with hydrogen positions.

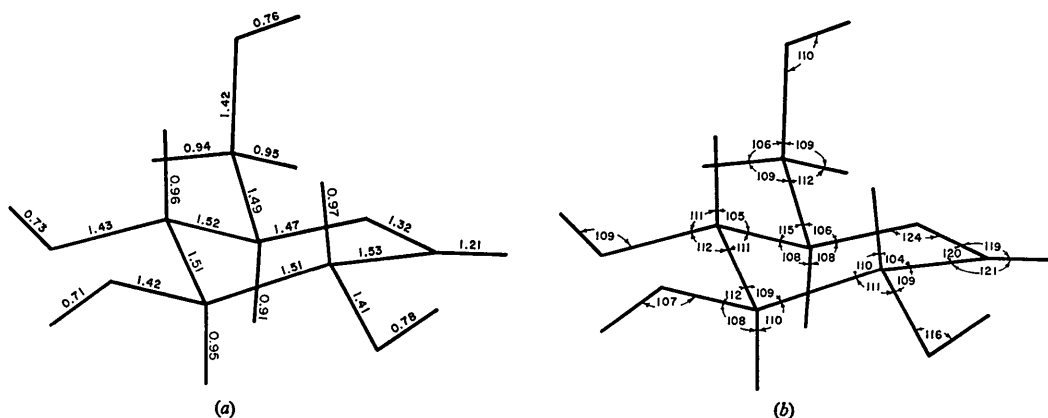

Fig. 3. (a) Bond distances, e.s.d. 0.03 Å and (b) bond angles, e.s.d. 2°.

double bond would assume the half-chair conformation (Pasternak, 1951) while those containing the lactone group would assume a boat conformation (McConnell, Mathieson & Schoenborn, 1962). The conformation of δ -lactones has since been studied by Cheung, Overton & Sim (1965). They confirmed the planarity of the lactone group but suggested that both the boat and half-chair conformations satisfy this condition in the δ -lactones.

For glucono- δ -lactone the lactone group carbon atom C(5) is 0.28 Å out of the best least-squares carbonyl plane formed by atoms C(1), O(1), C(2) and O(5) which are planar within 0.02 Å. This non-planarity of the lactone group has also been reported by Jeffrey & Kim (1966) for certain γ -lactones. For ring systems where the base atoms are not coplanar, the ring is best characterized by its dihedral angles, φ (Lambert, Car-

hart & Corfield, 1969). Using the ring of cyclohexane ($\varphi = 54.5^\circ$) as a reference, a molecule may be termed 'flattened' or 'puckered' depending upon whether φ is less than or greater than 54.5° . Comparison of the dihedral angles of various chair forms given in Table 5 indicates that the ring conformation of D-glucono-(1,5)-lactone can be best described as a distorted half-chair. The 'puckering' distortions are caused by the short bonds C(1)-O(5) and O(5)-C(5) (short compared with a C-C single bond), while the large C(5)-O(5)-C(1) angle allows for some 'flattening'. The requirements for minimum configuration energy are met by lowering C(5) out of and C(4) nearer to, the carbonyl plane resulting in a distorted half-chair conformation.

The crystal structure of D-glucono-(1,5)-lactone is shown in Fig. 2. As indicated from the equation of the best least-squares plane, the normal to the plane is

Table 5. Dihedral angles*

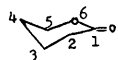
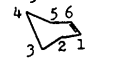
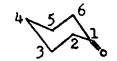
	φ (1,2)	φ (2,3)	φ (3,4)	φ (4,5)	φ (5,6)	φ (6,1)
(1) 	24.8 (3)	47.3 (3)	61.7 (2)	50.9 (3)	28.2 (3)	15.2 (4)
(2)† 	17.2	50.2	69.0	52.7	23.5	4.2
(3)‡ 	43.6 (8)	54.8 (7)	60.9 (6)	56.3 (7)	48.3 (8)	40.8 (8)

* The dihedral angle, φ , for a sixfold symmetric molecule with internal bond angles, θ , is given by

$$\cos \varphi = -\cos \theta / (1 + \cos \theta).$$

For cyclohexane ($\theta = 111.5^\circ$), $\varphi = 54.5^\circ$.

† From pentachlorocyclohexene (Pasternak, 1951).

‡ From 4,4-diphenylcyclohexanone (Lambert *et al.*, 1968).

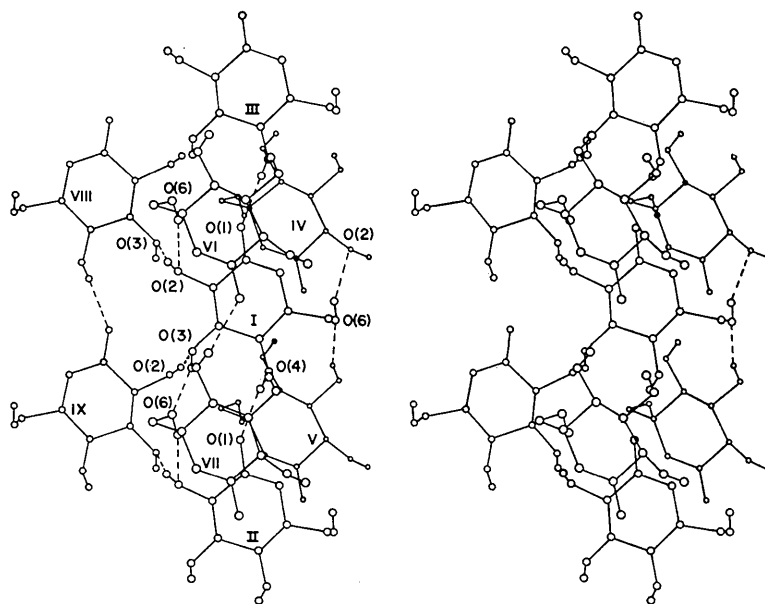

Fig. 4. Stereogram of hydrogen bonding in D-glucono-(1,5)-lactone showing molecule and its eight hydrogen-bond neighbors. I x, y, z ; II $x, y, 1+z$; III $x, y, -1+z$; IV $\frac{1}{2}+x, \frac{1}{2}-y, 1-z$; V $\frac{1}{2}+x, \frac{1}{2}-y, 2-z$; VI $-\frac{1}{2}+x, \frac{1}{2}-y, 1-z$; VII $-\frac{1}{2}+x, \frac{1}{2}-y, 2-z$; VIII $\frac{1}{2}-x, -y, -\frac{1}{2}+z$; IX $\frac{1}{2}-x, -y, \frac{1}{2}+z$.

Table 6. *Hydrogen bonds**

Bond <i>X-H---Y-M</i>	Distance			Angle	
	<i>X-H</i>	<i>H---Y</i>	<i>X---Y</i>	<i>X-H---Y</i>	<i>H---Y-M</i>
O(2, I)-H(2', I)---O(3, VIII)-C(3, VIII)	0.78 (3) Å	1.98 (3) Å	2.720 (3) Å	160 (3)°	132 (1)°
O(3, I)-H(3', I)---O(6, VII)-C(6, VII)	0.71 (3)	2.01 (4)	2.680 (3)	157 (4)	131 (1)
O(4, I)-H(4', I)---O(1, III)-C(1, III)	0.73 (3)	2.12 (3)	2.849 (3)	171 (3)	136 (1)
O(6, I)-H(6', I)---O(2, IV)-C(2, IV)	0.76 (3)	2.15 (4)	2.882 (3)	162 (3)	119 (1)

* Refer to Fig. 4.

nearly parallel with the x direction. The molecular packing in the crystal is largely dictated by intermolecular hydrogen bonds. There is also some ordering of the lactone dipoles in the x direction although the approximate separation of $a/2 = 3.9$ Å is so large that this effect is probably minor. The infrared spectrum contains a broad absorption band below 3500 cm^{-1} instead of between 3500 and 3700 cm^{-1} expected for unbound O-H groups. This is in agreement with the X-ray results which indicate a complete system of hydrogen bonds propagating three-dimensionally as shown in Fig. 4. The O---O lengths range from 2.68 to 2.88 Å in good agreement with a plot of stretching frequency *vs.* the O---O distance given by Nakamoto, Margoshes & Rundle (1955). The O-H groups bound to carbon atoms C(2), C(3) and C(6) participate in two hydrogen bonds, acting as a donor in one and acceptor in another. The C(4) O-H group acts only as a donor in a hydrogen bond involving an O(1) atom of an identically oriented molecule at a unit-cell translation in the z direction. Each molecule is hydrogen bonded to eight surrounding neighbors. The appropriate distances and angles are given in Table 6. It should be remembered that the angles given are based on the rather short O-H distances obtained by refining the X-ray data. Note that the H---Y-M angles somewhat approximate that expected for a distorted tetrahedral angle.

Conclusion

Inhibition studies of glycosidases have shown that the corresponding δ -aldonolactones are generally more efficient inhibitors than are the γ -lactones (Li, 1967; Conchie, Gelman & Levy, 1967). Certain polyols have also been found to inhibit glycosidases (Kelemen & Whelan, 1966), the most effective having a configuration similar to glucose between C(3) and C(6). Glucose also inhibits glycosidase activity, but Heyworth & Walker (1962) reported that the enzyme has a relatively low affinity for glucose compared with the glucono- δ -lactone.

Leaback (1968) has recently reaffirmed that the specificity and high affinity of the lactone for the enzyme probably arises from the conformational similarities between the lactone and the transition state of the normal substrate. Leaback also concluded that the high affinity of glycosidases for the corresponding δ -lactones was not a consequence of the lactone group itself, but of some property which it conferred to the

ring. It was postulated that the transition state involved an oxy-carbonium ion in a half-chair pyranose ring. This half-chair conformation was also expected for the δ -lactone ring. The results of this investigation provide detailed structural information about this important inhibitor and establish the stable conformation of the glucose half-chair ring.

The authors wish to acknowledge Professor Dexter French of the Iowa State University Biochemistry and Biophysics Department for his suggestion of the problem and helpful discussions. In addition to programs written in this laboratory for the IBM 360-65, other programs used in this work were Johnson's *ORTEP* to prepare Figs. 1, 2 and 4, Busing & Levy's *ORFFE* to calculate errors, and a local version of Neuman's *ORFLS-D* which is a modified version of Busing, Martin & Levy's *ORFLS*.

References

- BROWN, G. M. & LEVY, H. A. (1965). *Science*, **147**, 1038.
 CONCHIE, J., GELMAN, A. L. & LEVY, G. A. (1967). *Biochem. J.* **103**, 609.
 CHEUNG, K. K., OVERTON, K. H. & SIM, G. A. (1965). *Chem. Comm.* p. 634.
 DOYLE, P. A. & TURNER, P. S. (1968). *Acta Cryst.* **A24**, 390.
 HACKERT, M. L. & JACOBSON, R. A. (1969). *Chem. Comm.* p. 1179.
 HEYWORTH, R. & WALKER, P. G. (1962). *Biochem. J.* **83**, 331.
 JACOBSON, R. A. (1970). *Crystallographic Computing*, p. 81. Copenhagen: Munksgaard.
 JEFFREY, G. A. (1968). Private communication.
 JEFFREY, G. A. & KIM, S. H. (1966). *Chem. Comm.* p. 211.
 JENSEN, L. & SUNDARALINGAM, M. (1964). *Science*, **145**, 1185.
 KELEMEN, M. V. & WHELAN, W. J. (1966). *Arch. Biochem. Biophys.* **117**, 423.
 LAMBERT, J. B., CARHART, R. E. & CORFIELD, P. W. R. (1969). *J. Amer. Chem. Soc.* **91**, 3567.
 LEABACK, D. H. (1968). *Biochem. Biophys. Res. Comm.* **32** (6), 1025.
 LI, Y.-T. (1967). *J. Biol. Chem.* **242** (23), 5474.
 MATHIESON, A. McL. (1963). *Tetrahedron Letters*, **2**, 81.
 MCCONNELL, J. F., MATHIESON, A. McL. & SCHOENBORN, B. P. (1962). *Tetrahedron Letters*, **10**, 445.
 MIGHELL, A. D. & JACOBSON, R. A. (1963). *Acta Cryst.* **16**, 443.
 NAKAMOTO, K., MARGOSHES, M. & RUNDLE, R. E. (1955). *J. Amer. Chem. Soc.* **77**, 6480.
 PASTERNAK, R. A. (1951). *Acta Cryst.* **4**, 316.
 STEWART, R. F., DAVIDSON, E. R. & SIMPSON, W. T. (1965). *J. Chem. Phys.* **42**, 3175.